

**Nederman**

WMIA Partner of the Year



**S-Series  
Enclosureless Dust Collector**

# The S-Series (up to 5,000 CFM)

*Suitable for the collection of many different types of dust including wood, paper and plastic.*



## **Applications:**

*High Speed Routing • Sawing • Cutting • Single 'Cell' Manufacturing • After-Filters*

## **Benefits**

- *Single or three phase*
- *Easy installation*
- *Small footprint*
- *Thousands of successful installs*
- *Easy disposal using bags, drums or bins*
- *99.9% efficiency Patented SuperBags*
- *Quiet operation - less < 70 db(A) @ 10'*
- *NFPA Compliant for indoor use\**

## **Safety**

*Meets NFPA 664-2012, 3.3.10.2 and 8.2.2.5.1.4 (7) for Enclosureless Dust Collector less than 5000 CFM for Wood Dust*

*Meets NFPA 654-2013, 3.3.13 and 7.13.1.1.2 (4) for Enclosureless Dust Collector less than 3000 CFM for Combustible Solids*

# How it Works

## ...during normal operation

1. During normal operation, the dust laden air from the plant travels down the supply duct ①
2. The dirty air then enters the COMBIFAB ② material handling fan
3. The dust then enters the hopper section ⑤ of the filter
4. As air slows down within the hopper, the heavier dust particles fall down into the inside of the collection bags ⑥
5. The remaining dust then travels up into the inside of the filter bags ④
6. The air, which originated from the plant, is now clean and passes through the filter bag into the surrounding atmosphere ③

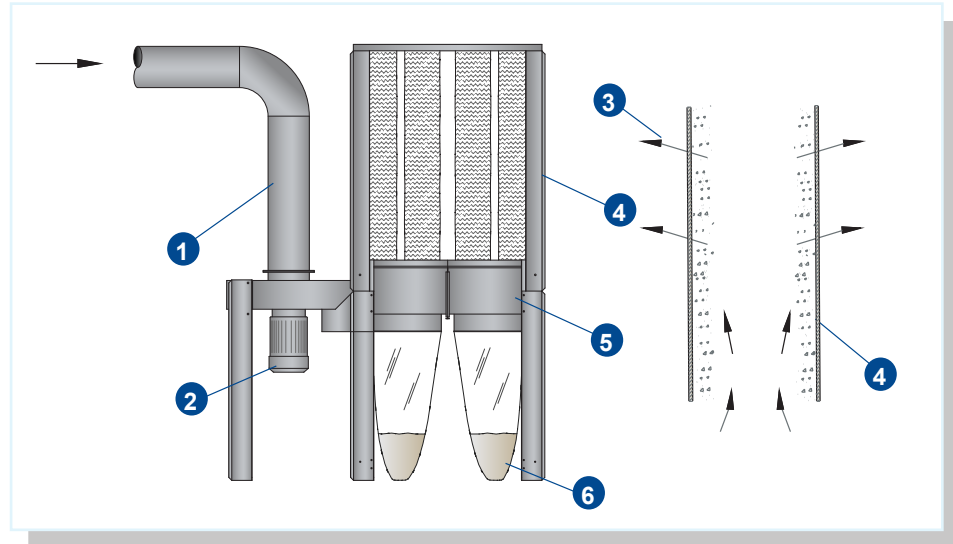

## ...while cleaning

1. The S Series may only clean "off-line", when the COMBIFAB fan ② has stopped rotating
2. The S Series is cleaned by applying physical force to the outside of the filter bag ④ which, in effect, shakes them
3. The dust cake, which hangs on the inside of the filter bag, falls into the hopper section and then into the collection bags below ⑥

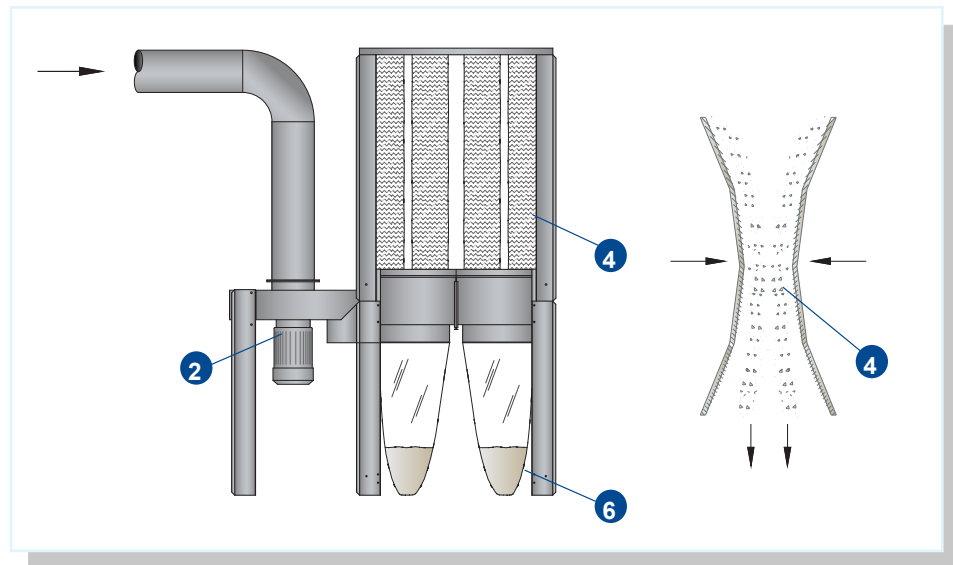

# The Nederman Difference

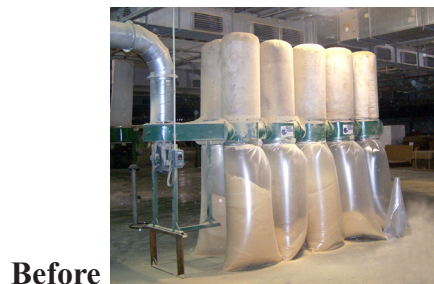

Before



After

# Unit Specifications

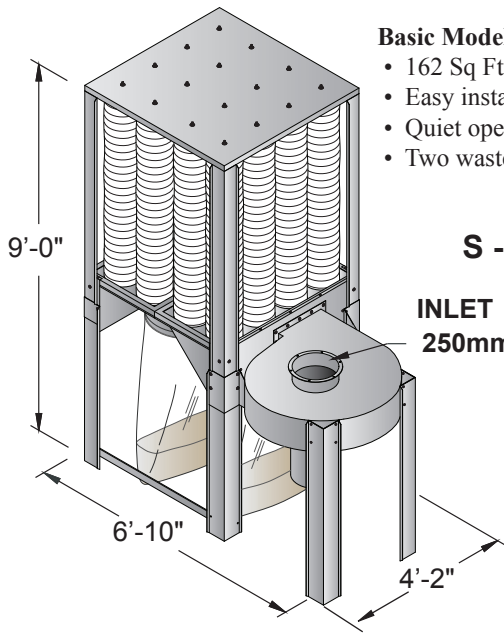

- Basic Model Features**
- 162 Sq Ft of filter media
  - Easy installation
  - Quiet operation
  - Two waste discharge points

**S - 500**

**INLET  
250mm**

- Basic Model Features**
- Qty (1) 5 HP, 1750 RPM, TEFC motor
  - Qty (16) Beane material filter bags
  - Qty (2) plastic waste collection bag
  - Qty (2) clamps for easy removal of waste bags

- Options**
- Available in 3-phase and 1-phase
  - Aluminium Fan Wheel
  - Motor Starters
  - Two 42 gallon drums
  - Inlet adapter to Nederman Quick-Fit, or raw edge
  - Complete Nederman Quick-Fit Duct packages
  - Available without fan as afterfilter

**CFM RANGE**

8.0" Wg	7.5" Wg	5.0" Wg
1500 CFM	2000 CFM	3000 CFM

Shipping Weight: 675lbs.

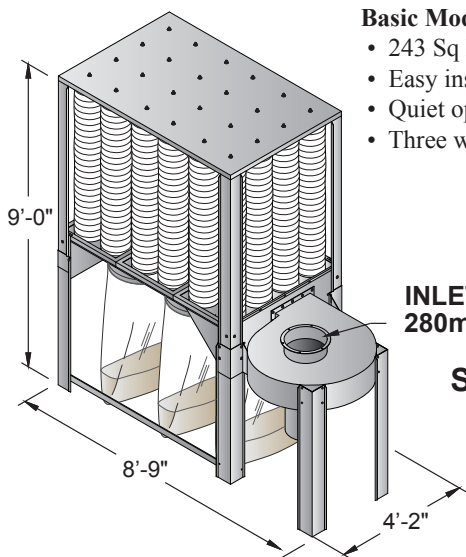

- Basic Model Features**
- 243 Sq Ft of filter media
  - Easy installation
  - Quiet operation
  - Three waste discharge points

**S - 750**

**INLET  
280mm**

- Basic Model Features**
- Qty (1) 7.5 HP, 1750 RPM, TEFC motor
  - Qty (24) Beane material filter bags
  - Qty (3) plastic waste collection bag
  - Qty (3) clamps for easy removal of waste bags

- Options**
- Available in 3-phase and 1-phase
  - Aluminium Fan Wheel
  - Motor Starters
  - Three 42 gallon drums
  - 230 gallon dump bin
  - Inlet adapter to Nederman Quick-Fit, or raw edge
  - Complete Nederman Quick-Fit Duct packages
  - Available without fan as afterfilter

**CFM RANGE**

10.0" Wg	8.0" Wg	6.0" Wg
2500 CFM	3500 CFM	4500 CFM

Shipping Weight: 900lbs.

# Unit Specifications

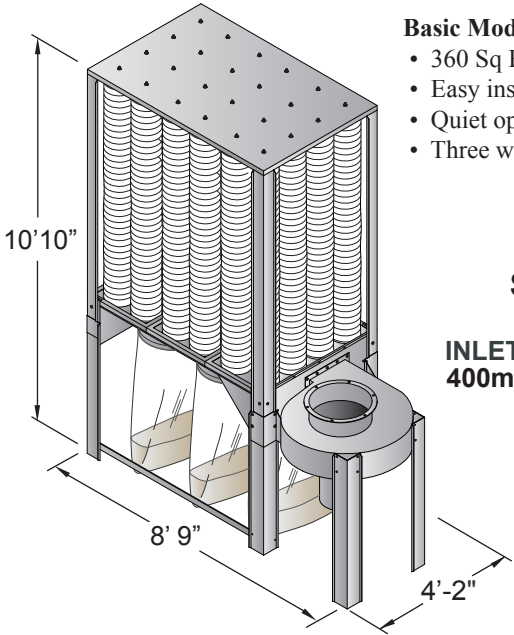

- Basic Model Features**
- 360 Sq Ft of filter media
  - Easy installation
  - Quiet operation
  - Three waste discharge points

**S - 1000**

**INLET  
400mm**

- Basic Model Features**
- Qty (1) 10 HP, 1750 RPM, TEFC motor, 3-phase
  - Qty (24) Beane material filter bags
  - Qty (3) plastic waste collection bag
  - Qty (3) clamps for easy removal of waste bags

- Options**
- Aluminium Fan Wheel
  - Motor Starters
  - Three 42 gallon drums
  - 230 gallon dump bin
  - Inlet adapter to Nederman Quick-Fit, or raw edge
  - Complete Nederman Quick-Fit Duct packages
  - Available without fan as afterfilter

**CFM RANGE**

8.0" Wg	7.0" Wg
4000 CFM	5000 CFM

Shipping Weight: 950lbs.

**Waste Disposal Options**



**Bags (Standard)**



**Barrels (Optional)**



**Dump Bin (Optional)**

**EASY AS 1-2-3**

Collector up and running in less than 1 hour

**1**



**2**



**3**



# The Superbag

## The Superbag

A filter is only as good as the filter bags it uses and this is the component that provides the filtering while allowing clean air to pass through with the least possible resistance. Therefore, the lowest possible consumption of energy is realized, even after several thousand hours of operation. Nederman patented filter bag, is fitted as the standard in all S-Series bag filters.



### Patented Weaving Process

Material stretches to improve cleaning/dust release  
Seamless bag body: maximizes usable filter area and improves efficiency

Low static resistance for maximum airflow

High filter efficiency for indoor use

Interwoven anti-static carbon fiber wire reduces static fire risk.

### Antistatic

Superbag's interwoven carbon fiber wire provides higher anti-static properties than traditional filter bags, both on the surface and inside. This reduces the risk of fire and explosion as fine particles are removed.

### High-End Filter Bag

Same material used in larger dust collectors

Superior performance with an economical design

Long life for reduced maintenance

No cage to wear holes in the bags.

# Dump Bin for the S-Series

**Dimensions:**

- Overall 33.0" wide x 70.5" long x 36.5" high
- Inside 29.0" wide x 66.5" long x 27.5" high

**Weight:**

500 lbs

**Volume:**

230 gallon  
[ 70% increased capacity over a (3) barrel outlet ]  
barrels are 45 gallon each

**Construction:**

14 ga galvanized steel



# Bringing superior conditions to the workplace and the environment

For more than 60 years Nederman has developed, manufactured and marketed products and system solutions to reduce the strain on the environment and improve working conditions in numerous industries.

Our products and systems have been ground-breaking in industries such as Machining, Metal Fabrication, Automotive, Composite Manufacturing, Food, Paper, Chemical, Pharmaceutical and many others.

Today companies all over the world are using equipment from Nederman.



**HERMANCE**  
*Machine Company*  
Wood • Plastics • Composites  
Industrial Machines Since 1902

**Nederman**

[www.nederman.com](http://www.nederman.com)

REGISTERED  
**ISO**  
9001:2008  
14001:2004

Nederman Sales companies in: Australia, Austria, Belgium, Brazil, Canada, China, Czech Rep., Denmark, France, Germany, Hungary, India, Ireland, Northern Ireland, Norway, Poland, Portugal, Romania, Russia, Slovakia, Spain, Sweden, Thailand, United Kingdom, USA  
Nederman Agents in: Bulgaria, Cyprus, Egypt, Estonia, Finland, Greece, Holland, Hong Kong, Iceland, Iran, Ireland, Italy, Japan, Korea, Latvia, Lithuania, Malaysia, New Zealand, Philippines, Saudi Arabia, Serbia, Singapore, Slovenia, South Africa, Switzerland, Taiwan, R.O.C, Thailand, Turkey, United Arab Emirates